

# Level Measurement

## Continuous level measurement – Radar transmitters

SITRANS LR200

### Overview

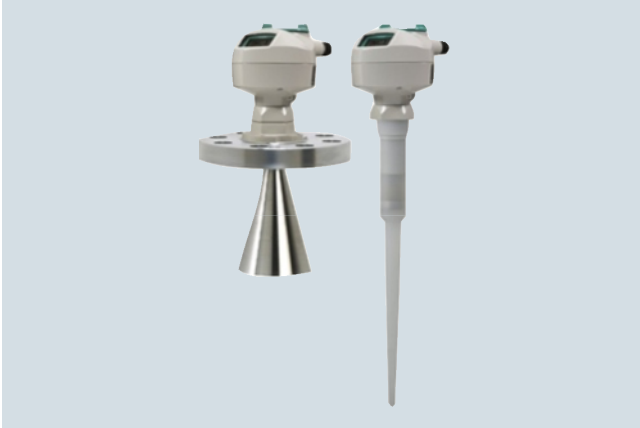

SITRANS LR200 is a 2-wire, 6 GHz pulse radar level transmitter for continuous monitoring of liquids and slurries in process vessels including high temperature, pressure, agitation, and turbulence to a range of 20 m (65 ft).

### Benefits

- Graphical local user interface (LUI) makes operation simple with plug-and-play setup using the intuitive Quick Start Wizard
- LUI displays echo profiles for diagnostic support
- Communication using HART or PROFIBUS PA
- Process Intelligence signal processing for improved measurement reliability and Auto False-Echo Suppression of fixed obstructions
- Programming using infrared Intrinsically Safe handheld programmer or SIMATIC PDM

### Application

SITRANS LR200's unique design allows safe and simple programming using the Intrinsically Safe handheld programmer without having to open the instrument's lid. It also features a built-in alphanumeric display in four languages.

The SITRANS LR200 has a standard Uni-Construction polypropylene rod antenna that offers excellent chemical resistance and is hermetically sealed. The Uni-Construction antenna features an internal, integrated shield that eliminates vessel nozzle interference.

Start-up is easy with as few as two parameters for basic operation. Installation is simplified as the electronics are mounted on a rotating head that swivels, allowing the instrument to line up with conduit or wiring connections or simply to adjust the position for easy viewing. SITRANS LR200 features patented Process Intelligence signal-processing technology for superior reliability.

- Key Applications: liquid process vessels with agitators, vaporous liquids, high temperatures, asphalt, digesters

### Configuration

#### Installation

Min. 300 mm (1 ft) for every 3 m (10 ft) of vessel wall.

#### Note:

- Beam angle is the width of the cone where the energy density is half of the peak energy density.
- Beam angle for horn antenna dependent on horn size
- The peak energy density is directly in front of and in line with the rod antenna.
- There is a signal transmitted outside of the beam angle; therefore false targets may be detected.

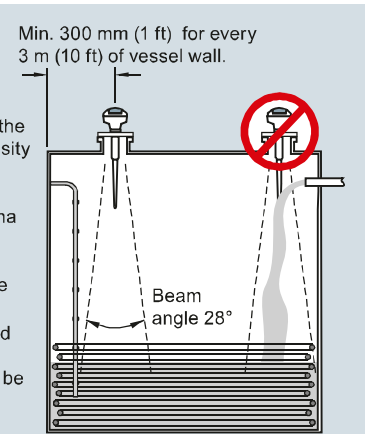

#### Mounting unit on vessel

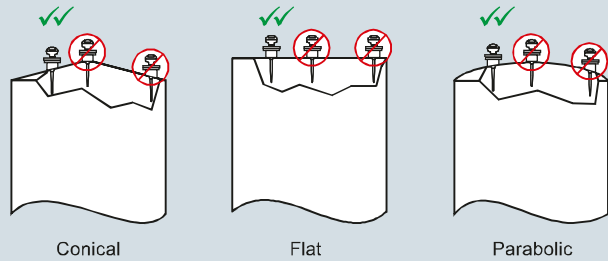

#### Mounting unit on stilling well

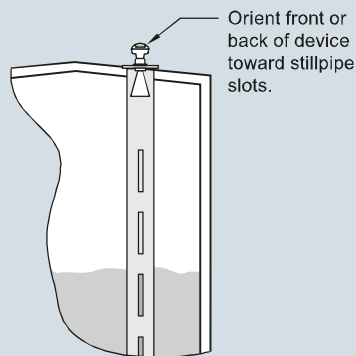

#### Mounting on a nozzle

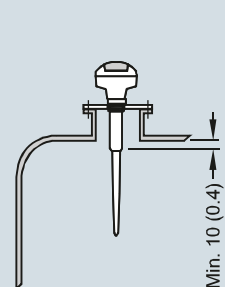

SITRANS LR200 installation, dimensions in mm (inch)

# Level Measurement

## Continuous level measurement – Radar transmitters

### SITRANS LR200

#### Technical specifications

<b>Mode of operation</b>		<b>Design</b>	
Measuring principle	Radar level measurement	Enclosure	Aluminum, polyester powder coated 2 x M20x1.5 or 2 x 1/2" NPT with adapter
Frequency	5.8 GHz (North America 6.3 GHz)	• Material	
Measuring range	0.3 ... 20 m (1.0 ... 65 ft)	• Cable inlet	
<b>Output</b>		Degree of protection	Type 4X/NEMA 4X, Type 6/ NEMA 6, IP67, IP68
• Analog output	4 ... 20 mA	Weight	< 2 kg (4.4 lb) (polypropylene rod antenna)
• Accuracy	± 0.02 mA	Display (local)	Multi-segment alphanumeric liquid crystal with bar graph (representing level) available in four languages
• Span	Proportional or inversely proportional	Antenna	Polypropylene rod, hermetically sealed construction, optional PTFE
• Communications	HART	• Material	
• Fail-safe	Optional: PROFIBUS PA (Profile 3.0, Class B) Programmable as high, low or hold (Loss of Echo)	• Dimensions	
<b>Performance (according to reference conditions IEC60770-1)</b>		• Optional rods, horn and waveguides	Standard 100 mm (4 inch) shield for maximum 100 mm (4 inch) nozzle, or optional 250 mm (10 inch) long shield Refer to SITRANS LR200 Antennas for optional rods, horns and waveguides
• From end of antenna to 600 mm:	40 mm (1.57 inch)	Process connections	1 1/2" NPT [(Taper), ANSI/ASME B1.20.1] R 1 1/2" [(BSPT), EN 10226], or G 1 1/2" [(BSPP), EN ISO 228-1] (polypropylene rod antenna) Refer to SITRANS LR200 Antennas for more connections
• Remainder of range:	10 mm (0.4 inch) or 0.1 % of span (whichever is greater)	• Process connection	
<b>Rated operating conditions</b>		• Flange connection	
Installation conditions	Indoor/outdoor	<b>Power supply</b>	Nominal 24 V DC (max. 30 V DC) with max. 550 Ω Nominal 24 V DC (max. 30 V DC) with max. 250 Ω
• Location			
Ambient conditions (enclosure)	-40 ... +80 °C (-40 ... +176 °F)	4 to 20 mA/HART	
• Ambient temperature		• General Purpose, Non-incendive, Intrinsically Safe	• per IEC 61158-2
• Installation category		• Flame proof, Increased safety, Explosion proof	
• Pollution degree	I	PROFIBUS PA	
	4		
<b>Medium conditions</b>			
• Dielectric constant $\epsilon_r$	$\epsilon_r > 1.6$ (for $\epsilon_r < 3$ , use waveguide antenna or stillpipe)		
• Vessel temperature and pressure	Varies with connection type; see Pressure/Temperature curves for more information		

# Level Measurement

## Continuous level measurement – Radar transmitters

SITRANS LR200

<b>Certificates and approvals</b>	
General	CSA <sub>US/C</sub> , CE, FM, C-TICK
Marine	<ul style="list-style-type: none"> <li>Lloyd's Register of Shipping</li> <li>ABS Type Approval</li> </ul>
Radio	FCC, Industry Canada and European (R&TTE), C-TICK
Hazardous	
<ul style="list-style-type: none"> <li>Intrinsically Safe (Brazil)</li> <li>Explosion Proof (Canada/USA)</li> </ul>	INMETRO Ex ia IIC T4 Ga CSA/FM, Class I, Div. 1, Groups A, B, C, D; Class II, Div. 1, Groups E, F, G; Class III, T4
<ul style="list-style-type: none"> <li>Intrinsically Safe (Canada/USA)</li> </ul>	CSA/FM, Class I, Div. 1, Groups A, B, C, D; Class II, Div. 1, Groups E, F, G; Class III, T4
<ul style="list-style-type: none"> <li>Non-incendive (USA)</li> </ul>	FM, Class I, Div. 2, Groups A, B, C, D, T5
<ul style="list-style-type: none"> <li>Flame Proof/Increased Safety (China)</li> <li>Flame Proof (Europe)</li> </ul>	NEPSI Ex d mb ia IIC T4/ Ex e mb ia IIC T4 ATEX II 1/2 G Ex d mb ia IIC T4 Ga/Gb
<ul style="list-style-type: none"> <li>Increased Safety (Europe)</li> </ul>	ATEX II 1/2 G Ex e mb ia IIC T4 Ga/Gb
<ul style="list-style-type: none"> <li>Intrinsically Safe (Europe)</li> <li>Intrinsically Safe (International)</li> <li>Intrinsically Safe (Russia)</li> </ul>	ATEX II 1G Ex ia IIC T4 IECEX Ex ia IIC T4 GOST-R Ex ia
<b>Programming</b>	
<ul style="list-style-type: none"> <li>Intrinsically Safe Siemens handheld programmer</li> <li>- Approvals for handheld programmer</li> </ul>	Infrared receiver  IS model: ATEX II 1GD Ex ia IIC T4 Ga Ex iaD 20 T135 °C T <sub>a</sub> = -20 ... +50 °C CSA/FM Class I, II, and III, Div. 1., Groups A, B, C, D, E, F, G, T6 T <sub>a</sub> = +50 °C
<ul style="list-style-type: none"> <li>Handheld communicator</li> <li>PC</li> </ul>	HART communicator 375 <ul style="list-style-type: none"> <li>SIMATIC PDM</li> <li>AMS</li> </ul>
<ul style="list-style-type: none"> <li>Display (local)</li> </ul>	Multi-segment alphanumeric liquid crystal with bar graph (representing level) available in four languages

# Level Measurement

## Continuous level measurement – Radar transmitters

### SITRANS LR200

#### Selection and Ordering data

Article No.

#### SITRANS LR200, Uni-Construction polypropylene rod antenna version

2-wire, 6 GHz pulse radar level transmitter for continuous monitoring of liquids and slurries in process vessels including high temperature and pressure, to a range of 20 m (66 ft).

Max. 3 bar g (43.5 psi g) pressure and 80 °C (176 °F)

#### Enclosure/Cable inlet

Aluminum, epoxy painted  
2 x 1/2" NPT  
2 x M20x1.5

#### Polypropylene antenna type - (Max. 3 Bar pressure and 80 °C)

1 1/2" NPT [(Taper), ANSI/ASME B1.20.1],  
c/w integral 100 mm shield  
R 1 1/2" [(BSPT), EN 10226],  
c/w integral 100 mm shield  
G 1 1/2" [(BSPP), EN ISO 228-1],  
c/w integral 100 mm shield

1 1/2" NPT [(Taper), ANSI/ASME B1.20.1],  
c/w integral 250 mm shield  
R 1 1/2" [(BSPT), EN 10226],  
c/w integral 250 mm shield  
G 1 1/2" [(BSPP), EN ISO 228-1],  
c/w integral 250 mm shield

#### Approvals

General Purpose, CE, R&TTE, C-TICK  
General Purpose, CSA, FM, Industry Canada, FCC  
Intrinsically Safe, CSA Class I, II, Div. 1, Groups A, B, C, D, E, F, G, Industry Canada

Intrinsically Safe, FM Class I, II, Div. 1, Groups A, B, C, D, E, F, G, FCC  
Intrinsically Safe, IECEx/ATEX II 1G Ex ia IIC T4,  
INMETRO Ex ia IIC T4, CE, R&TTE, C-TICK;  
GOST-R

Non incandive, FM Class I, Div. 2, Groups A, B, C, D, FCC<sup>1)</sup>

Increased Safety, ATEX II 1/2G Ex e mb ia IIC T4  
Ga/Gb, CE, R&TTE, C-TICK; GOST-R<sup>2)3)</sup>

Flame Proof, ATEX II 1/2G Ex d mb ia IIC T4 Ga/  
Gb, CE, R&TTE, C-TICK; GOST-R<sup>3)</sup>

Explosion Proof, CSA/FM Class I, II, III, Groups A, B, C, D, E, F, G, Industry Canada, FCC<sup>1)3)</sup>

#### Communication/Output

PROFIBUS PA  
4 ... 20 mA, HART, startup at < 3.6 mA

<sup>1)</sup> Available with enclosure option 2 only

<sup>2)</sup> Available with enclosure option 3 only

<sup>3)</sup> Available with communication option 3 only

7ML5422-  
0

A

B

C

D

E

F

A

B

C

D

E

F

G

H

J

2

3

#### Selection and Ordering data

Order code

#### Further designs

Please add "-Z" to Article No. and specify Order code(s).

Stainless steel tag [69 x 50 mm (2.71 x 1.97 inch)]:  
Measuring-point number/identification  
(max. 27 characters); specify in plain text

Y15

Manufacturer's test certificate: M to DIN 55350,  
Part 18 and to ISO 9000

C11

Namur NE43 compliant, device preset to failsafe  
< 3.6 mA<sup>1)</sup>

N07

#### Operating Instructions for HART/mA device

Article No.

English

7ML1998-5JP02

German

7ML1998-5JP32

Note: The Operating Instructions should be  
ordered as a separate line item on the order.

Multi-language Quick Start manual  
This device is shipped with the Siemens Milltronics  
manual DVD containing the ATEX Quick Start and  
Operating Instructions library.

A5E31993614

#### Operating Instructions for PROFIBUS PA device

English

7ML1998-5JR02

German

7ML1998-5JR32

Note: The Operating Instructions should be  
ordered as a separate line item on the order.

Multi-language Quick Start manual  
This device is shipped with the Siemens Milltronics  
manual DVD containing the ATEX Quick Start and  
Operating Instructions library.

A5E32153438

#### Accessories

Handheld programmer, Intrinsically safe, EEx ia

7ML1930-1BK

HART modem/RS 232  
(for use with a PC and SIMATIC PDM)

7MF4997-1DA

HART modem/USB  
(for use with a PC and SIMATIC PDM)

7MF4997-1DB

One metallic cable gland M20x1.5,  
rated -40 ... +80 °C (-40 ... +176 °F), HART<sup>2)</sup>

7ML1930-1AP

One metallic cable gland M20x1.5,  
rated -40 ... +80 °C (-40 ... +176 °F),  
PROFIBUS PA<sup>2)</sup>

7ML1930-1AQ

One general purpose polymeric cable gland  
M20x1.5, rated -20 ... +80 °C (-40 ... +176 °F)

7ML1930-1AM

SITRANS RD100 Remote display - see Chapter 7

SITRANS RD200 Remote display - see Chapter 7

SITRANS RD500 web, datalogging, alarming,  
ethernet, and modem support for instrumentation -  
see Chapter 7

7ML5750-  
1AA00-0

For applicable back up point level switch -  
see point level section on page 4/9

<sup>1)</sup> Available with communication option 3 only

<sup>2)</sup> Product shipped with plastic cable gland, rated to -20 °C.  
If -40 °C rating required, then metallic cable gland is recommended.

# Level Measurement

## Continuous level measurement – Radar transmitters

SITRANS LR200

Selection and Ordering data	Article No.	Selection and Ordering data	Article No.
<b>SITRANS LR200, Flange Adapter/PTFE Rod Antenna Version</b> 2-wire, 6 GHz pulse radar level transmitter for continuous monitoring of liquids and slurries in process vessels including high temperature and pressure, to a range of 20 m (66 ft).	7ML5423-	<b>SITRANS LR200, Flange Adapter/PTFE Rod Antenna Version</b> 2-wire, 6 GHz pulse radar level transmitter for continuous monitoring of liquids and slurries in process vessels including high temperature and pressure, to a range of 20 m (66 ft).	7ML5423-
<b>Antenna material (uses antenna adapter)</b> PTFE, uses antenna adapter and additional process connection below	1	<b>Communication/Output</b> PROFIBUS PA 4 ... 20 mA, HART, startup at < 3.6 mA	B C
<b>Process connection (refer to Pressure/Temperature curves, page 4/212)</b> Flanges (316L stainless steel) DN 50 PN 16, Type A, flat faced DN 80 PN 16, Type A, flat faced DN 100 PN 16, Type A, flat faced DN 150 PN 16, Type A, flat faced  2" ASME 150 lb, flat faced 3" ASME 150 lb, flat faced 4" ASME 150 lb, flat faced 6" ASME 150 lb, flat faced  DN 50 PN 40, flat faced DN 80 PN 40, flat faced DN 100 PN 40, flat faced DN 150 PN 40, flat faced  2" ASME 300 lb, flat faced, available with Pressure rating option 1 only due to flange hole spacing 3" ASME 300 lb, flat faced 4" ASME 300 lb, flat faced 6" ASME 300 lb, flat faced  JIS DN 50 10K JIS DN 80 10K JIS DN 100 10K JIS DN 150 10K (Note: Flange bolting patterns and facings dimensionally correspond to the applicable ASME B16.5, or EN 1092-1, or JIS B 2220 standard.)  Threaded connection (316L stainless steel) 1½" NPT [(Taper), ANSI/ASME B1.20.1] 2" NPT [(Taper), ANSI/ASME B1.20.1] R 1½" [(BSPT), EN 10226]  R 2" [(BSPT), EN 10226] G 1½" [(BSPP), EN ISO 228-1] G 2" [(BSPP), EN ISO 228-1]	AA BA CA DA  FB GB HB JB  AC BC CC DC FD  GD HD JD  AE BE CE DE	<b>Approvals</b> General Purpose, CE, R&TTE, C-TICK General Purpose, CSA FM, Industry Canada, FCC Intrinsically Safe, CSA Class I, II, Div. 1, Groups A, B, C, D, E, F, G, Industry Canada  Intrinsically Safe, FM Class I, II, Div. 1, Groups A, B, C, D, E, F, G, FCC  Intrinsically Safe, IECEx/ATEX II 1G Ex ia IIC T4, INMETRO Ex ia IIC T4, CE, R&TTE, C-TICK; GOST-R  Non incensive, FM Class I, Div. 2, Groups A, B, C, D, FCC <sup>2)</sup>  Increased Safety, ATEX II 1/2G Ex e mb ia IIC T4 Ga/Gb, CE, R&TTE, C-TICK; GOST-R <sup>3)4)</sup> Flame Proof, ATEX II 1/2G Ex d mb ia IIC T4 Ga/Gb, CE, R&TTE, C-TICK; GOST-R <sup>4)</sup> Explosion Proof, CSA/FM Class I, II, III, Groups A, B, C, D, E, F, G, Industry Canada, FCC <sup>2)4)</sup>	A B C  D  E  F  G  H  J
<b>Antenna extensions or Inactive shield length</b> No antenna extension 50 mm (2 inch) extension, PTFE 100 mm (4 inch) extension, PTFE  100 mm (4 inch) extension, 316L stainless steel shield <sup>1)</sup> 150 mm (6 inch) extension, 316L stainless steel shield <sup>1)</sup> 200 mm (8 inch) extension, 316L stainless steel shield <sup>1)</sup>  250 mm (10 inch) extension, 316L stainless steel shield <sup>1)</sup>	0 1 2  3 4 5  6	<b>Pressure rating</b> Rating per Pressure/Temperature curves in manual 0.5 bar g (7.25 psi g) maximum	0 1
<b>Process seal/gasket</b> Integral Gasket, for flat faced flange process connections only, not for Antenna extension options 3 ... 6 FKM O-ring, not available for combination of flat faced flanges with Antenna extension options 0, 1 or 2	0 1		
<b>Enclosure/Cable inlet</b> Aluminum, Epoxy painted 2 x ½" NPT 2 x M20x1.5	2 3		

4

1) Available with process connection options BA, CA, DA, GB, HB, JB, BC, CC, DC, GD, HD, JD, BE, CE, DE, MA, MC, ME only  
 2) Available with enclosure option 2 only  
 3) Available with enclosure option 3 only  
 4) Available with communication option C only

# Level Measurement

## Continuous level measurement – Radar transmitters

### SITRANS LR200

Selection and Ordering data	Article No.
<b>SITRANS LR200, Flange Adapter, Sanitary Version</b> 2-wire, 6 GHz pulse radar level transmitter for continuous monitoring of liquids and slurries in process vessels including high temperature and pressure, to a range of 20 m (66 ft).	<b>7ML5424-</b>
<b>Antenna material (uses antenna adapter)</b> PTFE, one piece rod antenna UHMW-PE, one piece rod antenna	0 1
<b>Process connection</b> Sanitary fitting clamp	A
<b>Configuration/Connection size</b> 2" connection, rod antenna only 3" connection, rod antenna only 4" connection, rod antenna only	A B C
<b>Antenna extension</b> No extension	0
<b>Mounting Clamp</b> No mounting clamp Mounting clamp included, not available with Pressure rating option 0	0 1
<b>Enclosure/Cable inlet</b> Aluminum, Epoxy painted 2 x 1/2" NPT 2 x M20x1.5	2 3
<b>Communication/Output</b> PROFIBUS PA 4 ... 20 mA, HART, startup at < 3.6 mA	B C
<b>Approvals</b> General Purpose, CE, R&TTE, C-TICK General Purpose, CSA, FM, Industry Canada, FCC Intrinsically Safe, CSA Class I, II, Div. 1, Groups A, B, C, D, E, F, G, Industry Canada Intrinsically Safe, FM Class I, II, Div. 1, Groups A, B, C, D, E, F, G, FCC Intrinsically Safe, IECEx/ATEX II 1G Ex ia IIC T4, INMETRO Ex ia IIC T4, CE, R&TTE, C-TICK; GOST-R Non incandive, FM Class I, Div. 2, Groups A, B, C, D, FCC <sup>1)</sup> Increased Safety, ATEX II 1/2G Ex e mb ia IIC T4 Ga/Gb, CE, R&TTE, C-TICK; GOST-R <sup>2)3)</sup> Flame Proof, ATEX II 1/2G Ex d mb ia IIC T4 Ga/Gb, CE, R&TTE, C-TICK; GOST-R <sup>3)</sup> Explosion Proof, CSA/FM Class I, II, III, Groups A, B, C, D, E, F, G, Industry Canada, FCC <sup>1)3)</sup>	A B C D E F G H J
<b>Pressure rating</b> Rating per Pressure/Temperature curves in Manual 0.5 bar g (7.25 psi g) maximum	0 1

<sup>1)</sup> Available with enclosure option 2 only

<sup>2)</sup> Available with enclosure option 3 only

<sup>3)</sup> Available with communication option C only

Selection and Ordering data	Order code
<b>Further designs</b> Please add "-Z" to Article No. and specify Order code(s). Stainless steel tag [69 x 50 mm (2.71 x 1.97 inch)]: Measuring-point number/identification (max. 27 characters); specify in plain text Manufacturer's test certificate: M to DIN 55350, Part 18 and to ISO 9000 Inspection Certificate Type 3.1 per EN 10204 Namur NE43 compliant, device preset to failsafe < 3.6 mA <sup>1)</sup>	<b>Y15</b> <b>C11</b> <b>C12</b> <b>N07</b>
<b>Operating Instructions for HART/mA device</b> English German Note: The Operating Instructions should be ordered as a separate line item on the order. Multi-language Quick Start manual This device is shipped with the Siemens Milltronics manual DVD containing the ATEX Quick Start and Operating Instructions library.	Article No. <b>7ML1998-5JP02</b> <b>7ML1998-5JP32</b> <b>A5E31993614</b>
<b>Operating Instructions for PROFIBUS PA device</b> English German Note: The Operating Instructions should be ordered as a separate line item on the order. Multi-language Quick Start manual This device is shipped with the Siemens Milltronics manual DVD containing the ATEX Quick Start and Operating Instructions library.	<b>7ML1998-5JR02</b> <b>7ML1998-5JR32</b> <b>A5E32153438</b>
<b>Accessories</b> Handheld programmer, Intrinsically safe, EEx ia HART modem/RS 232 (for use with a PC and SIMATIC PDM) HART modem/USB (for use with a PC and SIMATIC PDM) One metallic cable gland M20x1.5, rated -40 ... +80 °C (-40 ... +176 °F), HART <sup>2)</sup> One metallic cable gland M20x1.5, rated -40 ... +80 °C (-40 ... +176 °F), PROFIBUS PA <sup>2)</sup> One general purpose polymeric cable gland M20x 1.5, rated -40 ... +80 °C (-40 ... +176 °F) SITRANS RD100 Remote display - see Chapter 7 SITRANS RD200 Remote display - see Chapter 7 SITRANS RD500 web, datalogging, alarming, ethernet, and modem support for instrumentation - see Chapter 7 For applicable back up point level switch - see point level section on page 4/9	<b>7ML1930-1BK</b> <b>7MF4997-1DA</b> <b>7MF4997-1DB</b> <b>7ML1930-1AP</b> <b>7ML1930-1AQ</b> <b>7ML1930-1AM</b> <b>7ML5750-1AA00-0</b>
<b>Sanitary fitting clamps</b> 2", 304 stainless steel 3", 304 stainless steel 4", 304 stainless steel	<b>7ML1830-1HD</b> <b>7ML1830-1HE</b> <b>7ML1830-1HF</b>

<sup>1)</sup> Available with communication option C only

<sup>2)</sup> Product shipped with plastic cable gland, rated to -20 °C. If -40 °C rating required, then metallic cable gland is recommended.

# Level Measurement

## Continuous level measurement – Radar transmitters

SITRANS LR200

4

Selection and Ordering data	Order code
<b>Further designs</b>	
Please add <b>"-Z"</b> to Article No. and specify Order code(s).	
Stainless steel tag [69 x 50 mm (2.71 x 1.97 inch)]: Measuring-point number/identification (max. 27 characters); specify in plain text	<b>Y15</b>
Manufacturer's test certificate: M to DIN 55350, Part 18 and to ISO 9000	<b>C11</b>
Inspection Certificate Type 3.1 per EN 10204	<b>C12</b>
Namur NE43 compliant, device preset to failsafe < 3.6 mA <sup>1)</sup>	<b>N07</b>
<b>Operating Instructions for HART/mA device</b>	
English	<b>7ML1998-5JP02</b>
German	<b>7ML1998-5JP32</b>
Note: The Operating Instructions should be ordered as a separate line item on the order.	
Multi-language Quick Start manual This device is shipped with the Siemens Milltronics manual DVD containing the ATEX Quick Start and Operating Instructions library.	<b>A5E31993614</b>
<b>Operating Instructions for PROFIBUS PA device</b>	
English	<b>7ML1998-5JR02</b>
German	<b>7ML1998-5JR32</b>
Note: The Operating Instructions should be ordered as a separate line item on the order.	
Multi-language Quick Start manual This device is shipped with the Siemens Milltronics manual DVD containing the ATEX Quick Start and Operating Instructions library.	<b>A5E32153438</b>
<b>Accessories</b>	
Handheld programmer, Intrinsically safe, EEx ia HART modem/RS 232 (for use with a PC and SIMATIC PDM)	<b>7ML1930-1BK</b> <b>7MF4997-1DA</b>
HART modem/USB (for use with a PC and SIMATIC PDM)	<b>7MF4997-1DB</b>
One metallic cable gland M20x1.5, rated -40 ... +80 °C (-40 ... +176 °F), HART <sup>2)</sup>	<b>7ML1930-1AP</b>
One metallic cable gland M20x1.5, rated -40 ... +80 °C (-40 ... +176 °F), PROFIBUS PA <sup>2)</sup>	<b>7ML1930-1AQ</b>
Antenna, rod, PTFE	<b>7ML1830-1HC</b>
Antenna extension, 50 mm (2 inch) PTFE	<b>7ML1830-1CH</b>
Antenna extension, 100 mm (4 inch) PTFE	<b>7ML1830-1CG</b>
SITRANS RD100 Remote display - see Chapter 7	
SITRANS RD200 Remote display - see Chapter 7	
SITRANS RD500 web, datalogging, alarming, ethernet, and modem support for instrumentation - see Chapter 7	<b>7ML5750- 1AA00-0</b>

<sup>1)</sup> Available with communication option 3 only

<sup>2)</sup> Product shipped with plastic cable gland, rated to -20 °C.  
If -40 °C rating required, then metallic cable gland is recommended.



# Level Measurement

## Continuous level measurement – Radar transmitters

### SITRANS LR200

#### Selection and Ordering data

Article No.

#### SITRANS LR200,

#### Flange adapter/Horn Antenna version

2-wire, 6 GHz pulse radar level transmitter for continuous monitoring of liquids and slurries in process vessels including high temperature and pressure, to a range of 20 m (66 ft).

#### Antenna material (uses antenna adapter)

316L stainless steel with PTFE cone emitter  
316L stainless steel with PTFE cone emitter and purge connection with 1/8" NPT inlet<sup>1)</sup>  
Sliding waveguide system with 1 000 mm (40 inch) waveguide<sup>1)2)</sup>

#### Process connection (refer to Pressure/Temperature curves, page 4/212)

Flanges (316L stainless steel)

DN 50 PN 16 EN 1092-1 Type A flat faced<sup>1)</sup>  
DN 80 PN 16 EN 1092-1 Type A flat faced  
DN 100 PN 16 EN 1092-1 Type A flat faced  
DN 150 PN 16 EN 1092-1 Type A flat faced  
DN 200 PN 16 EN 1092-1 Type A flat faced

DN 80 PN 10/16 DIN EN 1092-1 Type B1 raised face<sup>3)</sup>  
DN 100 PN 10/16 DIN EN 1092-1 Type B1 raised face<sup>3)</sup>  
DN 150 PN 10/16 DIN EN 1092-1 Type B1 raised face<sup>3)</sup>  
DN 200 PN 16 DIN EN 1092-1 Type B1 raised face<sup>3)</sup>

2" ASME 150 lb, flat faced<sup>1)</sup>

3" ASME 150 lb, flat faced

4" ASME 150 lb, flat faced

6" ASME 150 lb, flat faced

8" ASME 150 lb, flat faced

DN 50 PN 40, flat faced<sup>3)</sup>

DN 80 PN 40, flat faced<sup>3)</sup>

DN 100 PN 40, flat faced<sup>3)</sup>

DN 200 PN 40, flat faced<sup>3)</sup>

DN 80 PN 25/40 DIN EN 1092-1 Type B1 raised face<sup>3)</sup>

DN 100 PN 25/40 DIN EN 1092-1 Type B1 raised face<sup>3)</sup>

DN 150 PN 25/40 DIN EN 1092-1 Type B1 raised face<sup>3)</sup>

DN 200 PN 25/40 DIN EN 1092-1 Type B1 raised face<sup>3)</sup>

2" ASME 300 lb, flat faced<sup>1)3)</sup>

3" ASME 300 lb, flat faced<sup>3)</sup>

4" ASME 300 lb, flat faced<sup>3)</sup>

JIS DN 50 10K<sup>1)</sup>

JIS DN 80 10K

JIS DN 100 10K

JIS DN 150 10K

JIS DN 200 10K

(Note: Flange bolting patterns and facings dimensionally correspond to the applicable

ASME B16.5, or EN 1092-1, or JIS B 2220 standard.)

#### Communication/Output

PROFIBUS PA

4 ... 20 mA, HART, startup at < 3.6 mA

7ML5425-

0	
1	
2	
AA	
BA	
CA	
DA	
EA	
BF	
CF	
DF	
EF	
FB	
GB	
HB	
JB	
KB	
AC	
BC	
CC	
EC	
CG	
DG	
EG	
FD	
GD	
HD	
AE	
BE	
CE	
DE	
EE	
1	
2	

#### Selection and Ordering data

Article No.

#### SITRANS LR200,

#### Flange adapter/Horn Antenna version

2-wire, 6 GHz pulse radar level transmitter for continuous monitoring of liquids and slurries in process vessels including high temperature and pressure, to a range of 20 m (66 ft).

#### Process seal/gasket

FKM (-40 ... +200 °C)  
Nitrile (-40 ... +60 °C),  
sliding waveguide systems only  
FFKM (-35 ... +200 °C)

#### Enclosure/Cable inlet

Aluminum, Epoxy painted

2 x 1/2" NPT

2 x M20x1.5

#### Horn size/Waveguide options

80 mm (3 inch) horn<sup>4)</sup>

100 mm (4 inch) horn<sup>4)</sup>

150 (6 inch) mm horn

200 (8 inch) mm horn

100 mm (4 inch) horn with 100 mm (4 inch)

waveguide extension<sup>4)</sup>

100 mm (4 inch) horn with 150 mm (6 inch)

waveguide extension<sup>4)</sup>

100 mm (4 inch) horn with 200 mm (8 inch)

waveguide extension<sup>4)</sup>

100 mm (4 inch) horn with 250 mm (10 inch)

waveguide extension<sup>4)</sup>

150 mm (6 inch) horn with 100 mm (4 inch)

waveguide extension

150 mm (6 inch) horn with 150 mm (6 inch)

waveguide extension

150 mm (6 inch) horn with 200 mm (8 inch)

waveguide extension

150 mm (6 inch) horn with 250 mm (10 inch)

waveguide extension

200 mm (8 inch) horn with 100 mm (4 inch)

waveguide extension

200 mm (8 inch) horn with 150 mm (6 inch)

waveguide extension

200 mm (8 inch) horn with 200 mm (8 inch)

waveguide extension

200 mm (8 inch) horn with 250 mm (10 inch)

waveguide extension

(Add Order code Y01 and plain text:

"waveguide length ... mm")

7ML5425-

0	
1	
2	
2	
3	
B	
C	
D	
E	
F	
G	
H	
J	
K	
L	
M	
N	
P	
Q	
R	
S	



# Level Measurement

## Continuous level measurement – Radar transmitters

SITRANS LR200

Selection and Ordering data	Article No.	Selection and Ordering data	Order code
<b>SITRANS LR200, Flange adapter/Horn Antenna version</b> 2-wire, 6 GHz pulse radar level transmitter for continuous monitoring of liquids and slurries in process vessels including high temperature and pressure, to a range of 20 m (66 ft).	<b>7ML5425-</b> 	<b>Further designs</b> Please add "-Z" to Article No. and specify Order code(s).	
<b>Approvals</b> General Purpose, CE, R&TTE, C-TICK General Purpose, CSA, FM, Industry Canada, FCC Intrinsically Safe, CSA Class I, II, Div. 1, Groups A, B, C, D, E, F, G, Industry Canada Intrinsically Safe, FM Class I, II, Div. 1, Groups A, B, C, D, E, F, G, FCC Intrinsically Safe, IECEx/ATEX II 1G Ex ia IIC T4, INMETRO Ex ia IIC T4, CE, R&TTE, C-TICK; GOST-R Non incandive, FM Class I, Div. 2, Groups A, B, C, D, FCC <sup>5)</sup> Increased Safety, ATEX II 1/2G Ex e mb ia IIC T4 Ga/Gb, CE, R&TTE, C-TICK; GOST-R <sup>6)7)</sup> Flame Proof, ATEX II 1/2G Ex d mb ia IIC T4 Ga/Gb, CE, R&TTE, C-TICK; GOST-R <sup>7)</sup> Explosion Proof, CSA/FM Class I, II, III, Groups A, B, C, D, E, F, G, Industry Canada, FCC <sup>5)7)</sup>	<b>A</b> <b>B</b> <b>C</b> <b>D</b> <b>E</b> <b>F</b> <b>G</b> <b>H</b> <b>J</b>	Inactive custom shield lengths: Enter the total length of the inactive shield in plain text description (in 1 mm increments). <b>Y01</b> Stainless steel tag [69 x 50 mm (2.71 x 1.97 inch)]: Measuring-point number/identification (max. 27 characters); specify in plain text <b>Y15</b> Manufacturer's test certificate: M to DIN 55350, Part 18 and to ISO 9000 <b>C11</b> Inspection Certificate Type 3.1 per EN 10204 <b>C12</b> Namur NE43 compliant, device preset to failsafe < 3.6 mA <sup>1)</sup> <b>N07</b>	
<b>Pressure rating</b> Rating per Pressure/Temperature curves in manual 0.5 bar g (7.25 psi g) maximum <b>0</b> <b>1</b>		<b>Operating Instructions for HART/mA device</b> English <b>7ML1998-5JP02</b> German <b>7ML1998-5JP32</b> Note: The Operating Instructions should be ordered as a separate line item on the order. Multi-language Quick Start manual This device is shipped with the Siemens Milltronics manual DVD containing the ATEX Quick Start and Operating Instructions library. <b>A5E31993614</b>	
1) Available with pressure rating option 1 only 2) Maximum Process Temperature 60 °C (140 °F) 3) Available with Antenna Material option 0 and 1 only 4) For stillpipe applications only 5) Available with enclosure option 2 only 6) Available with enclosure option 3 only 7) Available with communication option 2 only		<b>Operating Instructions for PROFIBUS PA device</b> English <b>7ML1998-5JR02</b> German <b>7ML1998-5JR32</b> Note: The Operating Instructions should be ordered as a separate line item on the order. Multi-language Quick Start manual This device is shipped with the Siemens Milltronics manual DVD containing the ATEX Quick Start and Operating Instructions library. <b>A5E32153438</b>	
		<b>Accessories</b> Handheld programmer, Intrinsically safe, EEx ia HART modem/RS 232 (for use with a PC and SIMATIC PDM) <b>7ML1930-1BK</b> <b>7MF4997-1DA</b> HART modem/USB (for use with a PC and SIMATIC PDM) <b>7MF4997-1DB</b> One metallic cable gland M20x1.5, rated -40 ... +80 °C (-40 ... +176 °F), HART <sup>2)</sup> <b>7ML1930-1AP</b> One metallic cable gland M20x1.5, rated -40 ... +80 °C (-40 ... +176 °F), PROFIBUS PA <sup>3)</sup> <b>7ML1930-1AQ</b> One general purpose polymeric cable gland M20x1.5, rated -40 ... +80 °C (-40 ... +176 °F) <b>7ML1930-1AM</b> SITRANS RD100 Remote display - see Chapter 7 SITRANS RD200 Remote display - see Chapter 7 SITRANS RD500 web, datalogging, alarming, ethernet, and modem support for instrumentation - see Chapter 7 <b>7ML5750-1AA00-0</b> For applicable back up point level switch - see point level section on page 4/9	
		1) Available with communication option 2 only 2) Product shipped with plastic cable gland, rated to -20 °C. If -40 °C rating required, then metallic cable gland is recommended. 3) Available with enclosure option 2 only	

# Level Measurement

## Continuous level measurement – Radar transmitters

### SITRANS LR200

#### Dimensional drawings

4

**SITRANS LR200 with polypropylene shielded rod antenna**

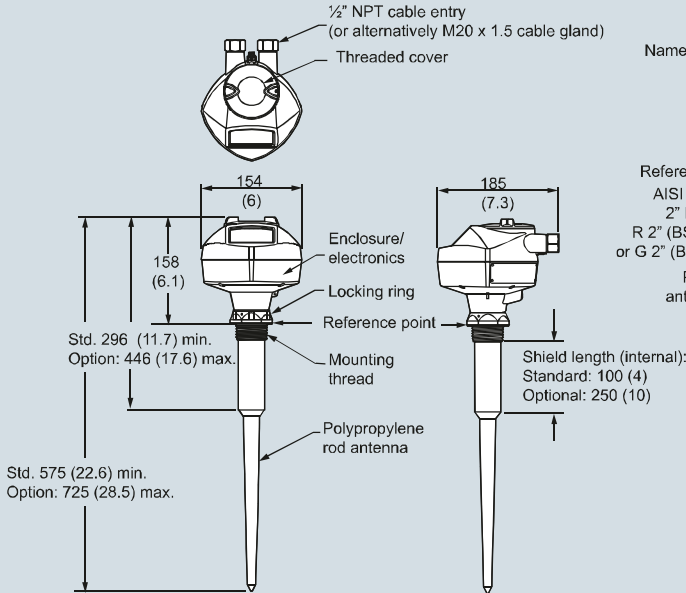

**PTFE rod antenna, threaded**

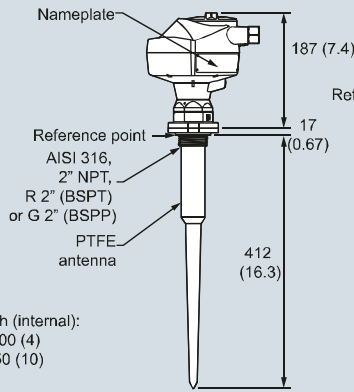

**Threaded connection PTFE rod, external shield**

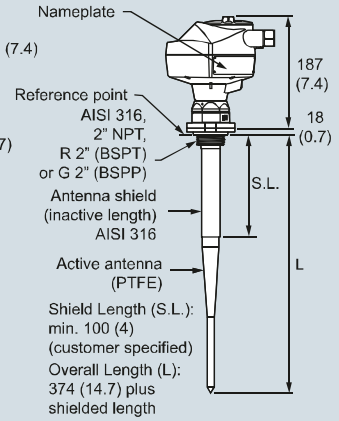

**Horn antenna with flat faced flange**

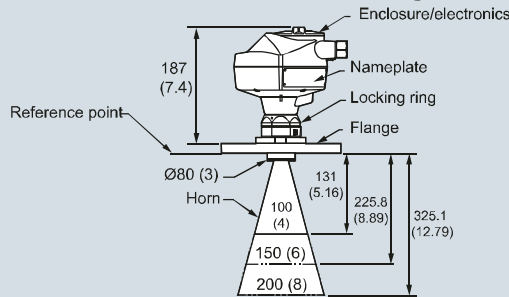

**Sliding waveguide**

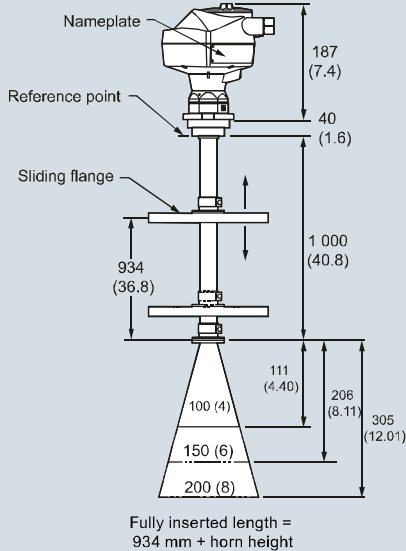

**Sanitary rod antenna**

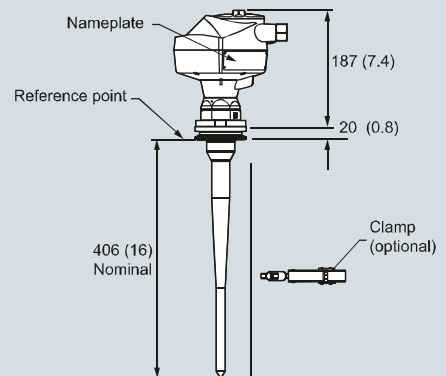

SITRANS LR200, dimensions in mm (inch)

# Level Measurement

## Continuous level measurement – Radar transmitters

SITRANS LR200

### Schematics

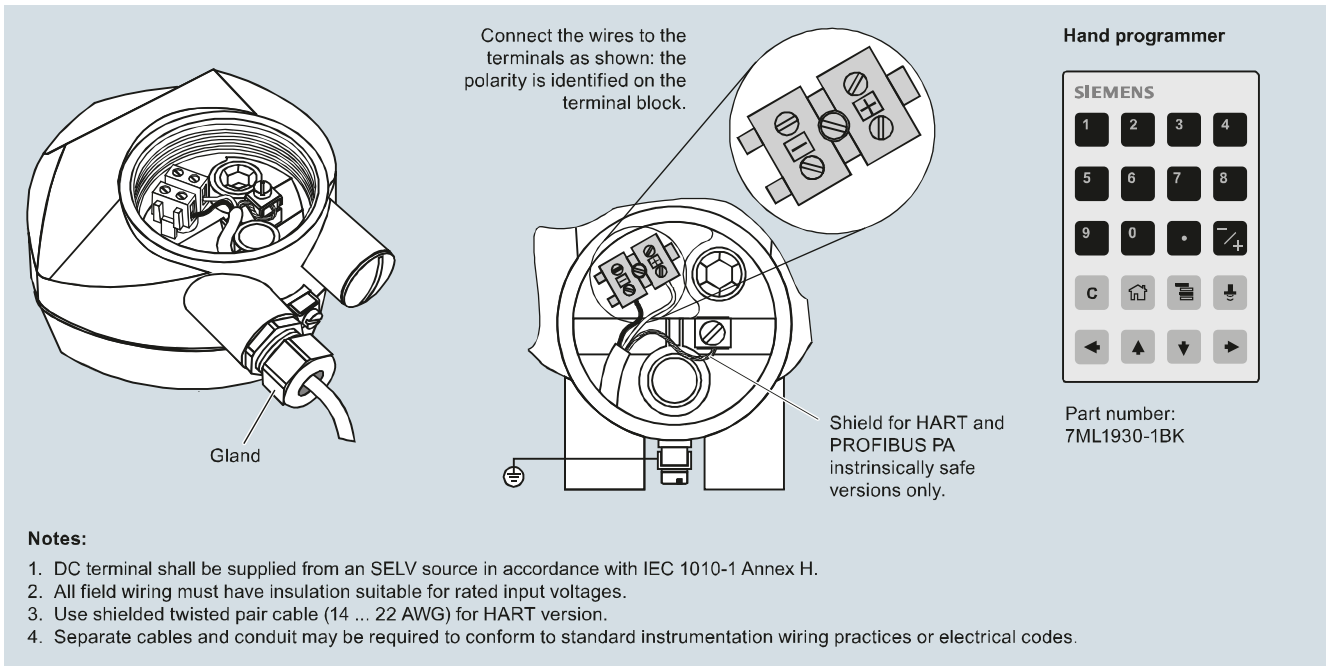

SITRANS LR200 connections

# Level Measurement

## Continuous level measurement – Radar transmitters

### SITRANS LR200 Antennas

#### Integration



Antenna configurations for SITRANS LR200

#### Technical specifications

Antenna Types	Flat Faced Flange with Rod	Shielded Rod	Sanitary Rod (1 piece construction)	Horn (4", 6", 8" sizes available)
<b>Connection type</b>	Flat faced flange nominal pipe sizes 50, 80, 100, 150 mm (2, 3, 4, 6 inch)	Threaded 2" NPT, R 2" (BSPT), G 2" (BSPP) or flat faced flange nominal pipe sizes 80, 100 mm (3, 4 inch)	Sanitary fitting clamp 50, 80, 100 mm (2, 3, 4 inch) sizes	Flat faced flange nominal pipe sizes 50, 80, 100, 150 mm (2, 3, 4, 6 inch)
<b>Wetted parts</b>	PTFE	PTFE, 316L stainless steel, FKM o-ring	UHME-PE or PTFE	316L stainless steel PTFE, FKM o-ring
<b>Extensions</b>	50 or 100 mm (2 or 4 inch) PTFE or UHMW-PE	100, 150, 200 or 250 mm (4, 6, 8 or 10 inch) standard shield length	N/A	Use waveguide for extensions to 6 m (20 ft) long
<b>Dielectric constant</b>	> 3	> 3	> 3	> 3
<b>Insertion length (max.)</b>	41 cm (16.3 inch)	Variable	41 cm (16.3 inch)	Variable with extension
<b>Purging option (liquid or gas)</b>	No	No	No	Yes
<b>Sliding waveguide option for digesters<sup>1)</sup></b>	Yes	No	No	Yes
<b>Weight<sup>2)</sup></b>	6.5 kg (14.3 lb)	5.0 kg (11 lb)	5.0 kg (11 lb)	7.5 kg (16.5 lb)

<sup>1)</sup> Maximum pressure 0.5 bar g at 60 °C (7.25 psi g at 140 °F)

<sup>2)</sup> Not including extensions, includes SITRANS LR200 and smallest process connection

# Level Measurement

## Continuous level measurement – Radar transmitters

SITRANS LR200 Antennas

### Characteristic curves

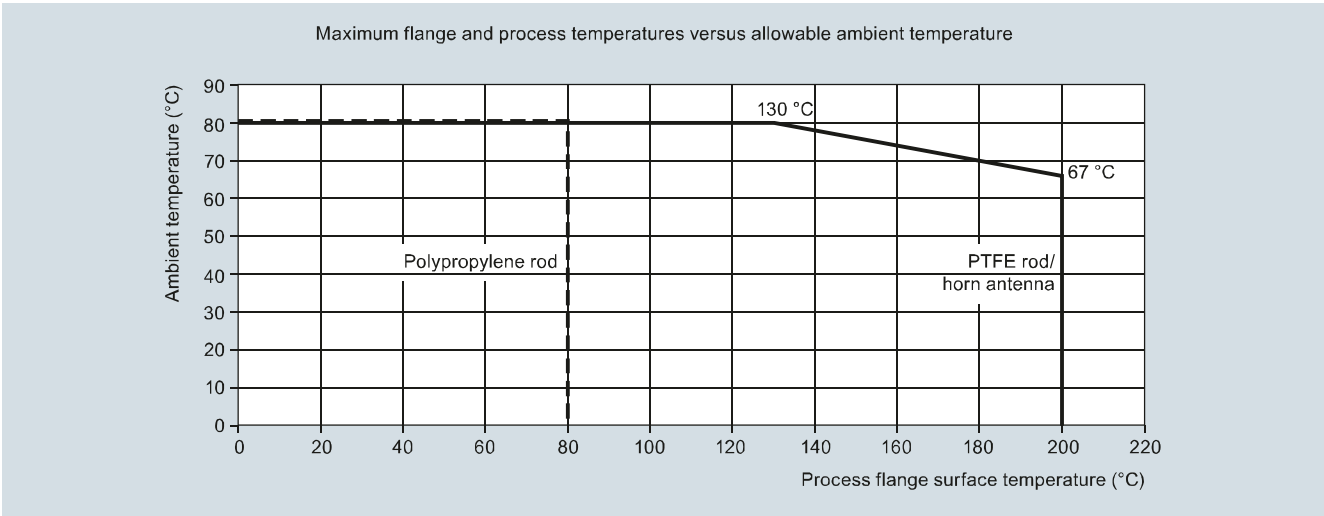

SITRANS LR200 Ambient/Process Flange Surface Temperature Curve

4

# Level Measurement

## Continuous level measurement – Radar transmitters

### SITRANS LR200 Antennas

4

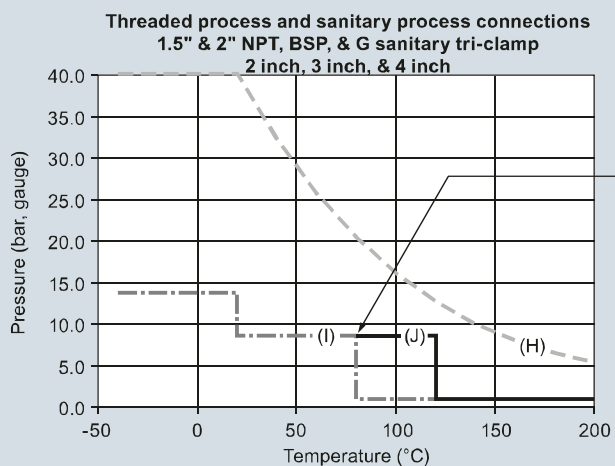
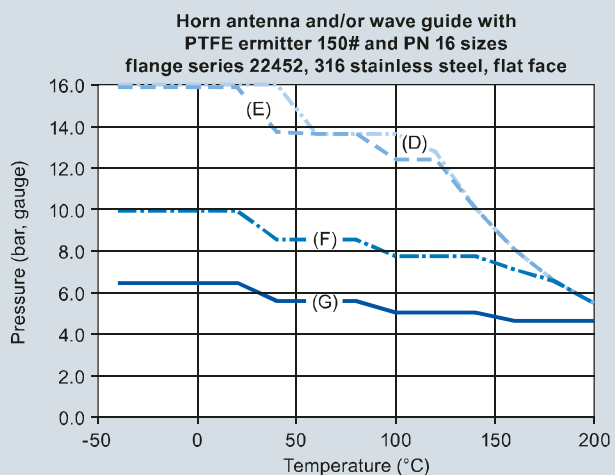
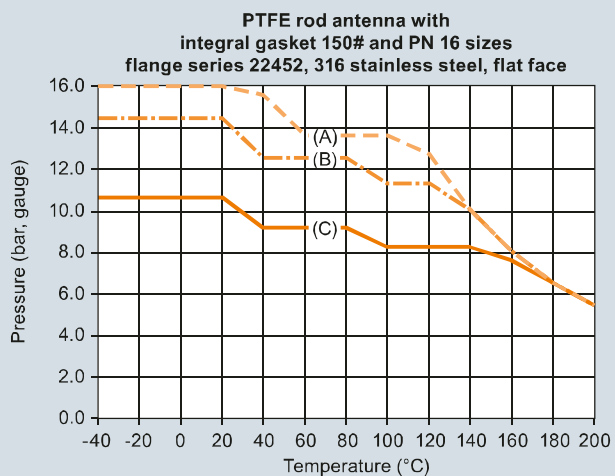



UHMW-PE is limited to 80 °C, it can be used to 120 °C for short (3 hrs) durations at ambient pressure, no stress applied to the antenna.

SITRANS LR200 Process Pressure/Temperature derating curves

# Level Measurement

## Continuous level measurement – Radar transmitters

### SITRANS LR200 Specials

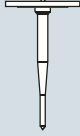
SITRANS LR200 Specials		SITRANS LR200 Specials	
	Article No.		Article No.
<b>SITRANS LR200 PROFIBUS PA Aluminum Enclosure Kit with electronics and covers (7ML5422, 7ML5423, 7ML5424, 7ML5425), calibrated for use with standard rod antenna</b>		SITRANS LR200 aluminum enclosure with board stack, LUI display, 5.8 GHz, NPT cable inlet, approval option A, with HART communication start-up at < 3.6 mA, no process connection. <sup>5)</sup>	<b>A5E03617085</b>
	<b>A5E01483420</b>	SITRANS LR200 aluminum enclosure with board stack, LUI display, 6.3 GHz, NPT cable inlet, approval option B, with HART communication start-up at < 3.6 mA, no process connection. <sup>5)</sup>	<b>A5E03617086</b>
	<b>A5E01483440</b>	SITRANS LR200 aluminum enclosure with board stack, LUI display, 5.8 GHz, NPT cable inlet, approval option C, with HART communication start-up at < 3.6 mA, no process connection. <sup>5)</sup>	<b>A5E03617087</b>
	<b>A5E01483456</b>	SITRANS LR200 aluminum enclosure with board stack, LUI display, 6.3 GHz, NPT cable inlet, approval option E, with HART communication start-up at < 3.6 mA, no process connection. <sup>5)</sup>	<b>A5E03617088</b>
	<b>A5E01483547</b>	SITRANS LR200 aluminum enclosure with board stack, LUI display, 6.3 GHz, NPT cable inlet, approval option C, with PROFIBUS PA communication, no process connection. <sup>5)</sup>	
<b>SITRANS LR200 HART aluminum enclosure kit with electronics and covers (7ML5422, 7ML5423, 7ML5424, 7ML5425), calibrated for use with standard rod antenna</b>		SITRANS LR200 aluminum enclosure with board stack, LUI display, 5.8 GHz, NPT cable inlet, approval option E, with PROFIBUS PA communication, no process connection. <sup>5)</sup>	
	<b>A5E01483559</b>		
	<b>A5E02956419</b>	80 mm (3 inch) horn antenna kit	<b>PBD:25500K02A</b>
	<b>A5E02956420</b>	100 mm (4 inch) horn antenna kit	<b>PBD:25500K03A</b>
	<b>A5E02956421</b>	150 mm (6 inch) horn antenna kit	<b>PBD:25500K05A</b>
<b>A5E02956422</b>	200 mm (8 inch) horn antenna kit	<b>PBD:25500K07A</b>	
		<b>SITRANS LR200 Extension Kits for Horn Antenna with mounting screws</b>	
		100 mm (4 inch) extension kit for horn antenna	<b>PBD:25501K0100A</b>
		150 mm (6 inch) extension kit for horn antenna	<b>PBD:25501K0150A</b>
		200 mm (8 inch) extension kit for horn antenna	<b>PBD:25501K0200A</b>
		250 mm (10 inch) extension kit for horn antenna	<b>PBD:25501K0250A</b>
		500 mm (20 inch) extension kit for horn antenna	<b>PBD:25501K0500A</b>
		1 000 mm (40 inch) extension kit for horn antenna	<b>PBD:25501K1000A</b>
		<b>SITRANS LR200 Flanged Rod Antenna Kit with 316L stainless steel flat faced flanges</b>	
			
		Flanged PTFE rod antenna kit, 2" ASME, 150 lb. See drawing 51003 on <a href="http://www.siemens.com/radar">http://www.siemens.com/radar</a> . <sup>1)4)</sup>	<b>PBD: 51003K020AAAA</b>
		Flanged PTFE rod antenna kit, DN 50 PN 16. See drawing 51003 on <a href="http://www.siemens.com/radar">http://www.siemens.com/radar</a> . <sup>1)4)</sup>	<b>PBD: 51003K050AJAA</b>
		Flanged PTFE rod antenna kit, JIS 10K DN 50. See drawing 51003 on <a href="http://www.siemens.com/radar">http://www.siemens.com/radar</a> . <sup>1)4)</sup>	<b>PBD: 51003K050AOAA</b>



# Level Measurement

## Continuous level measurement – Radar transmitters

### SITRANS LR200 Specials

#### SITRANS LR200 Specials

Article No.

#### SITRANS LR200 PTFE Rod Antenna Kit with 316L stainless steel 1½" pipe thread process connection



PTFE rod antenna kit, 1½" NPT 316L stainless steel process connection, FKM O-ring; See drawing 51004 on <http://www.siemens.com/radar>.<sup>4)</sup>

**PBD:**  
**51004K1AAA**

PTFE rod antenna kit, R 1½" (BSPT), EN 10226 316L stainless steel process connection, FKM O-ring; see drawing 51004 on <http://www.siemens.com/radar>.<sup>4)</sup>

**PBD:**  
**51004K2AAA**

PTFE rod antenna kit, 1½" G 316L stainless steel process connection, FKM O-ring; see drawing 51004 on <http://www.siemens.com/radar>.<sup>4)</sup>

**PBD:**  
**51004K3AAA**

#### SITRANS LR200 PTFE Rod Antenna Kit with 316L stainless steel 2" pipe thread process connection



PTFE rod antenna kit, 2" NPT 316L stainless steel process connection, FKM O-ring; see drawing 51005 on <http://www.siemens.com/radar>.<sup>4)</sup>

**PBD:**  
**51005K1AAA**

PTFE rod antenna kit, R 2" (BSPT), EN 10226 316L stainless steel process connection, FKM O-ring; see drawing 51005 on <http://www.siemens.com/radar>.<sup>4)</sup>

**PBD:**  
**51005K2AAA**

PTFE rod antenna kit, 2" G 316L stainless steel process connection, FKM O-ring; see drawing 51005 on <http://www.siemens.com/radar>.<sup>4)</sup>

**PBD:**  
**51005K3AAA**

#### SITRANS LR200 Specials

Article No.

#### SITRANS LR200 PTFE Rod Antenna Kit (100 mm shield) with 316L stainless steel 2" pipe thread process connection



PTFE rod antenna shielded kit, 2" NPT 316L stainless steel process connection, FKM O-ring, 100 mm 316L stainless steel shield. See drawing 51002 on <http://www.siemens.com/radar>.<sup>3)4)</sup>

**PBD:**  
**51002K0100AAA**

PTFE rod antenna shielded kit, R 2" (BSPT), EN 10226 316L stainless steel process connection, FKM O-ring, 100 mm 316L stainless steel shield. See drawing 51002 on <http://www.siemens.com/radar>.<sup>3)4)</sup>

**PBD:**  
**51002K0100BAA**

PTFE rod antenna shielded kit, 2" G 316L stainless steel process connection, FKM O-ring, 100 mm 316L stainless steel shield. See drawing 51002 on <http://www.siemens.com/radar>.<sup>3)4)</sup>

**PBD:**  
**51002K0100CAA**

#### SITRANS LR200 Horn Antenna Kit with 316L stainless steel flat faced flange, with PTFE emitter (without waveguide)

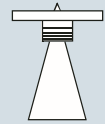

Horn antenna kit, 2" ASME 316L stainless steel flange 3" horn, PTFE emitter<sup>1)4)</sup>

**PBD:**  
**51006K020AAAA**

Horn antenna kit, 2" ASME 316L stainless steel flange 4" horn, PTFE emitter<sup>1)2)</sup>

**PBD:**  
**51006K020AABA**

Horn antenna kit, 2" ASME 316L stainless steel flange 6" horn, PTFE emitter<sup>1)2)</sup>

**PBD:**  
**51006K020AACA**

Horn antenna kit, 2" ASME 316L stainless steel flange 8" horn, PTFE emitter<sup>1)2)</sup>

**PBD:**  
**51006K020AADA**

Horn antenna kit, DN 50 PN 16 316L stainless steel flange 80 mm horn, PTFE emitter<sup>1)2)</sup>

**PBD:**  
**51006K050AJAA**

Horn antenna kit, DN 50 PN 16 316L stainless steel flange 100 mm horn, PTFE emitter<sup>1)2)</sup>

**PBD:**  
**51006K050AJBA**

Horn antenna kit, DN 50 PN 16 316L stainless steel flange 150 mm horn, PTFE emitter<sup>1)2)</sup>

**PBD:**  
**51006K050AJCA**



Horn antenna kit, DN 50 PN 16 316L stainless steel flange 200 mm horn, PTFE emitter<sup>1)2)</sup>

**PBD:**  
**51006K050AJDA**

# Level Measurement

## Continuous level measurement – Radar transmitters

### SITRANS LR200 Specials

SITRANS LR200 Specials	Article No.
<b>SITRANS LR200 Sanitary Rod Antenna with Sanitary Fitting Clamp Flange mounting and bushing.</b> <b>See drawing 51010 on</b> <a href="http://www.siemens.com/radar">http://www.siemens.com/radar</a> <b>(Sanitary Fitting Clamps not included)</b>	
PTFE sanitary rod antenna kit, 2" mounting connection. <sup>4)</sup>	<b>PBD:51010K1AA</b>
PTFE sanitary rod antenna kit, 3" mounting connection. <sup>4)</sup>	<b>PBD:51010K2AA</b>
PTFE sanitary rod antenna kit, 4" mounting connection. <sup>4)</sup>	<b>PBD:51010K3AA</b>
UHMW-PE sanitary rod antenna kit, 2" mounting connection. <sup>4)</sup>	<b>PBD:51010K1AB</b>
UHMW-PE sanitary rod antenna kit, 3" mounting connection. <sup>4)</sup>	<b>PBD:51010K2AB</b>
UHMW-PE sanitary rod antenna kit, 4" mounting connection. <sup>4)</sup>	<b>PBD:51010K3AB</b>
<b>SITRANS LR200 PTFE flanged rod antenna kit with 316L stainless steel shield and 316L stainless steel flat faced flange</b>	
PTFE shielded rod antenna kit, flanged, 3" ASME 150 lb 316L stainless steel flange, 100 mm 316L stainless steel shield. <sup>1)4)</sup>	<b>PBD: 51014K0100AAA</b>
PTFE shielded rod antenna kit, flanged, DN 80 PN 16 316L stainless steel flange, 100 mm 316L stainless steel shield. <sup>1)4)</sup>	<b>PBD: 51014K0100EJA</b>
PTFE shielded rod antenna kit, flanged, 3" ASME 150 lb 316L stainless steel flange, 150 mm 316L stainless steel shield. <sup>1)4)</sup>	<b>PBD: 51014K0150AAA</b>
PTFE shielded rod antenna kit, flanged, DN 80 PN 16 316L stainless steel flange, 150 mm 316L stainless steel shield. <sup>1)4)</sup>	<b>PBD: 51014K0150EJA</b>
PTFE shielded rod antenna kit, flanged, 3" ASME 150 lb 316L stainless steel flange, 200 mm 316L stainless steel shield. <sup>1)4)</sup>	<b>PBD: 51014K0200AAA</b>
PTFE shielded rod antenna kit, flanged, DN 80 PN 16 316L stainless steel flange, 200 mm 316L stainless steel shield. <sup>1)4)</sup>	<b>PBD: 51014K0200EJA</b>
PTFE shielded rod antenna kit, flanged, 3" ASME 150 lb 316L stainless steel flange, 250 mm 316L stainless steel shield. <sup>1)4)</sup>	<b>PBD: 51014K0250AAA</b>
PTFE shielded rod antenna kit, flanged, DN 80 PN 16 316L stainless steel flange, 250 mm 316L stainless steel shield. <sup>1)4)</sup>	<b>PBD: 51014K0250EJA</b>

SITRANS LR200 Specials	Article No.
<b>PTFE paste</b> Kit, PTFE paste, Tube, 250 mL	<b>PBD:51036065</b>
<b>Cable gland</b> One polymeric cable gland M20x1.5, rated -20 ... +80 °C (-4 ... +176 °F) for General Purpose and ATEX EEx e	<b>7ML1930-1AN</b>
One metallic cable gland M20x1.5, rated -40 ... +80 °C (-40 ... +176 °F), HART	<b>7ML1930-1AP</b>
One metallic cable gland M20x1.5, rated -40 ... +80 °C (-40 ... +176 °F), PROFIBUS PA	<b>7ML1930-1AQ</b>
Please contact <a href="mailto:ceg.smpi@siemens.com">ceg.smpi@siemens.com</a> for special requests.	
<sup>1)</sup> Available in flange sizes including ASME, DIN and JIS: please contact <a href="mailto:ceg.smpi@siemens.com">ceg.smpi@siemens.com</a> .	
<sup>2)</sup> Available with no pressure rating	
<sup>3)</sup> Available in other shield lengths: please contact <a href="mailto:ceg.smpi@siemens.com">ceg.smpi@siemens.com</a> .	
<sup>4)</sup> Available with Pressure rating; serial number of original unit required with completed Application Questionnaire found on page 4/11	